

Key Performance Features

- Air Cooled
- IP65 Rating
- Brushless Design
- High Load capacity
- Long bearing life

Applications

- Small Vehicles
- Carts
- AGV's

WM34

BRUSHLESS
WHEEL
MOTOR

Performance Characteristics

Part Number	Operating Voltage	Continuous Rating			Peak	
		Wheel Torque	Wheel Speed		Wheel Torque	
WM34-36	12-36	2.0 ft x lb	60-200 RPM	0.5-1.6 MPH w/ 8in Wheel	69-208 Watts	10.0 ft x lb
WM34-72	24-72					
WM34-285	95-285					

Note: Systems are rated for 5:1 ratio of continuous power operation to peak power operation in a duty cycle.

Technical Features

- Holding Break rated for full motor torque
- Holding Break available for 2 – 285V applications
- 440# load capacity rating
- 28000 bearing life at rated load
- Custom Connectors available
- Encoder operating voltages 5V or 5-24V
- 1024 PPR quadrature encoder signal with commutation and reference pulse
- 8 pole motor
- 24:1 gerabox

How to order:

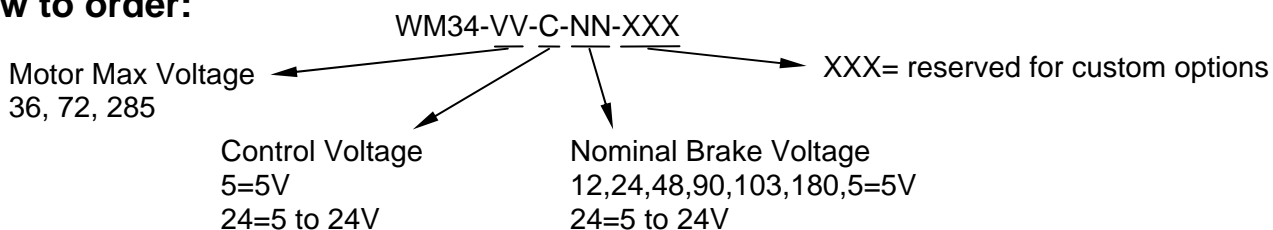

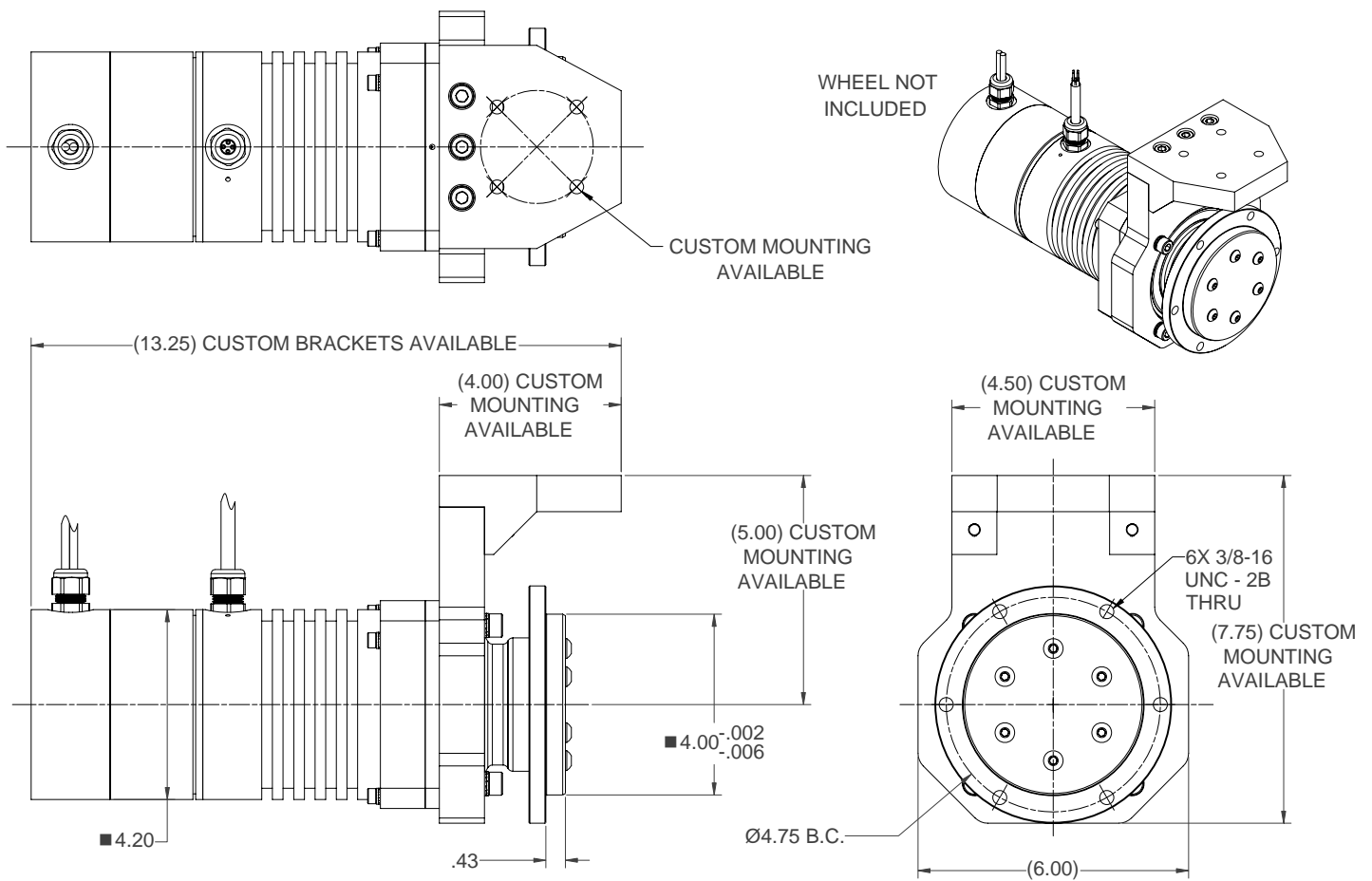

Connections

Control Connections (Flying Leads):

Red (28awg):	Encoder Positive	Green (28awg):	B^ Incremental Output
Black (28awg):	Encoder Ground	Orange (28awg):	Z Incremental Output
Violet (28awg):	U Motor Commutation	Yellow (28awg):	Z^ Incremental Output
Gray (28awg):	U^ Motor Commutation	Drain Wire (28awg):	Shield Drain (Not grounded)
Brown/White (28awg):	V Motor Commutation	Black/White (28awg):	Encoder Housing Ground
Red/White (28awg):	V^ Motor Commutation	2 x Black (18awg)	Brake power
Orange/White (28awg):	W Motor Commutation		
Yellow/White (28awg):	W^ Motor Commutation		
Brown (28awg):	A Incremental Output	Motor Connections (Flying Leads):	
White (28awg):	A^ Incremental Output	Red (16awg)	Motor Phase A, 1
Blue (28awg):	B Incremental Output	Black (16awg)	Motor Phase B, 2
		White (16awg)	Motor Phase C, 3

Environmental

- IP65 Rating with proper wire terminations
- Aluminum Finish: Chromium Conversion coating.
- Gearhead Finish: Black Oxide
- Operating Temperature Range: -10C to 30C